

# DN-DMX8030 DMX512 Decoder



DN-DMX8030DMX512 decoder adopts the advanced dimming technology to convert universal DMX512 signal to PWM signal to drive LED, DMX decoder can be controlled by DMX512 console, Each channel output with 256 grey scales, realize 0-100% brightness and various program changes, It can control single color, two-color, RGB color LED lamps.

## 1. Produce Parameter:

Power Supply Chosen	DC CV SMPS
Input Voltage	DC5V~DC24V
Max Load Current	4A/CH×3CH 12A Max
Max Output Power	60W/144W/288W(5V/12V/24V)
Output Scale Level	256 levels(8 Bit/CH)
Input Signal	DMX512
DMX512 socket	Standard XLR-3, Green Terminal
Working Temperature	-30°C~65°C
Dimension	L125×W52×H40mm
Package Size	L135×W70×H50mm
Weight (G.W.)	300g

## 2. Configuration Diagram:

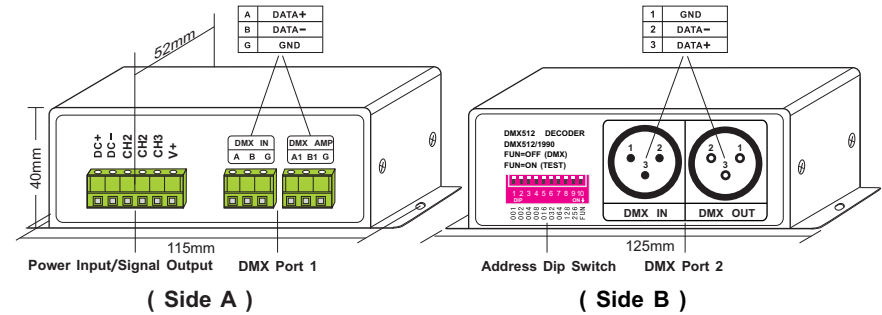

## 3. Set Initial DMX Address:

Accept DMX512 signal only when the DIP switch FUN=OFF, as figure 1.

DIP	1	2	3	4	5	6	7	8	9
Value	001	002	004	008	016	032	064	128	256
<b>Remark</b>									
DMX512 initial address is the total amount of the Dip switch 1-9, down dip switch to "ON" position, User can get its place value, Up dip switch to "OFF" position, Its place value is 0.									

### Example1: Set Initial Address to 37

Set the 1<sup>st</sup>, 3<sup>rd</sup>, 6<sup>th</sup>, bit of the DIP switch downward to "1" the rest to "0" (like figure 2), the summation from 1 to 9 is 1+4+32, so the DMX512 initial address code is 37.

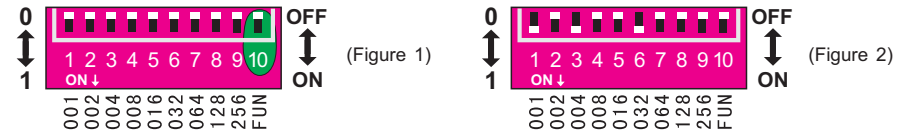

## 4. DMX Dimming Instruction:

Each DN-DMX8030DMX decoder occupies 3 DMX address when connecting the DMX console. For instance, defaulting the initial address for the DMX decoder is 1, please find their corresponding relationships in the following form.

DMX Console Channel	DMX Decoder Output Channel
CH1 0-255	CH1 PWM 0-100% (LED R)
CH2 0-255	CH2 PWM 0-100% (LED G)
CH3 0-255	CH3 PWM 0-100% (LED B)

## 5. Test Function:

### 1. Manual Dimming Functions:

As figure, while FUN=OFF, disconnect the DMX512 signal, entering the manual dimming with the dip switch.

Brightness	DIP1-3(CH1)	DIP4-6(CH2)	DIP7-9(CH3)
0	000	000	000
14%	100	100	100
28%	010	010	010
43%	110	110	110
57%	001	001	001
71%	101	101	101
86%	011	011	011
100%	111	111	111

### 2. Automatic Functions:

As figure, FUN=ON: test function; 1-9DIP switch=OFF: BLACK.

DIP1	DIP2	DIP3	DIP4	DIP5	DIP6	DIP7	DIP8	DIP9
Red	Green	Blue	Yellow	Purple	Cyan	full brightness	Strobe	Color gradual

DIP8/DIP9=ON : change modes. DIP switch 1-7 is to realize 8 speed leavels. 7 is the fastest levels, dip switch 1-7=OFF: the speed is 0.

DIP1	DIP2	DIP3	DIP4	DIP5	DIP6	DIP7
Speed 1	Speed 2	Speed 3	Speed 4	Speed 5	Speed 6	Speed 7

As figure, when several dip switches are on, subjected to the highest switch value, when all the dip switches=ON,it's the color gradual in the test mode,7 speed level

## 6. Configuration Diagram:

### 1. Many Decoder are Powered by One Power Supply:

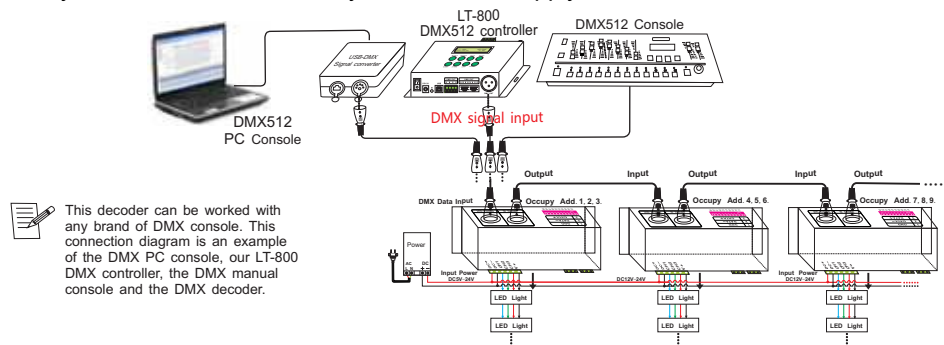

3

### 2. Each Decoder is Powered by One Power Supply Independently:

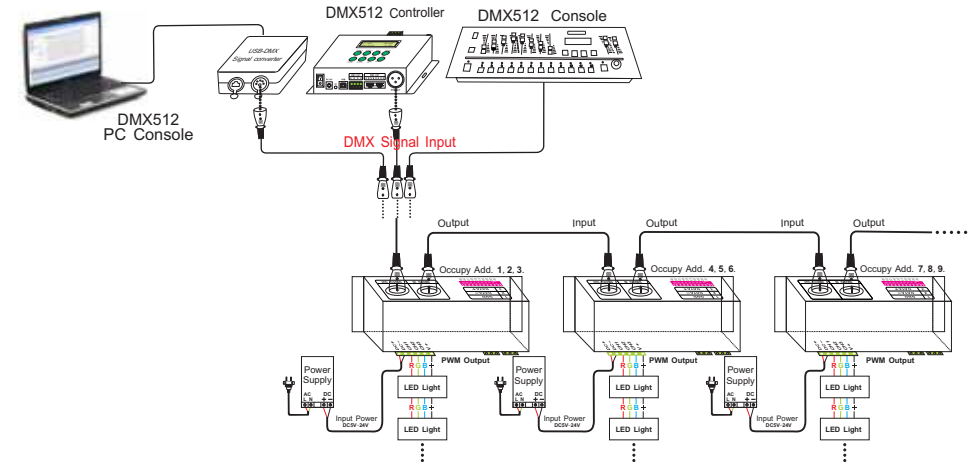

## 7. Attention

- 1) The product shall be installed and serviced by a qualified person.
- 2) This product is non-waterproof. Please avoid the sun and rain. When installed outdoors please ensure it is mounted in a water proof enclosure.
- 3) Good heat dissipation will prolong the working life of the controller. Please ensure good ventilation.
- 4) Please check if the output voltage of any LED power supplies used comply with the working voltage of the product.
- 5) Please ensure that adequate sized cable is used from the controller to the LED lights to carry the current. Please also ensure that the cable is secured tightly in the connector.
- 6) Ensure all wire connections and polarities are correct before applying power to avoid any damages to the LED lights.
- 7) If a fault occurs please return the product to your supplier. Do not attempt to fix this product by yourself.

## 8. Warranty Agreement:

- 1) We provide lifelong technical assistance with this product:
  - A 5-year warranty is given from the date of purchase. The warranty is for free repair or replacement and covers manufacturing faults only.
  - For faults beyond the 5-year warranty we reserve the right to charge for time and parts.
- 2) Warranty exclusions below:
  - Any man-made damages caused from improper operation, or connecting to excess voltage and overloading.
  - The product appears to have excessive physical damage.
  - Damage due to natural disasters and force majeure.
  - Warranty label, fragile label and unique barcode label have been damaged.
  - The product has been replaced by a brand new product.
- 3) Repair or replacement as provided under this warranty is the exclusive remedy to the customer. Dinam shall not be liable for any incidental or consequential damages for breach of any stipulation in this warranty.
- 4) Any amendment or adjustment to this warranty must be approved in writing by Dinam only.

★ This manual only applies to this model. Ltech reserves the right to make changes without prior notice.

4